

**BTX™**

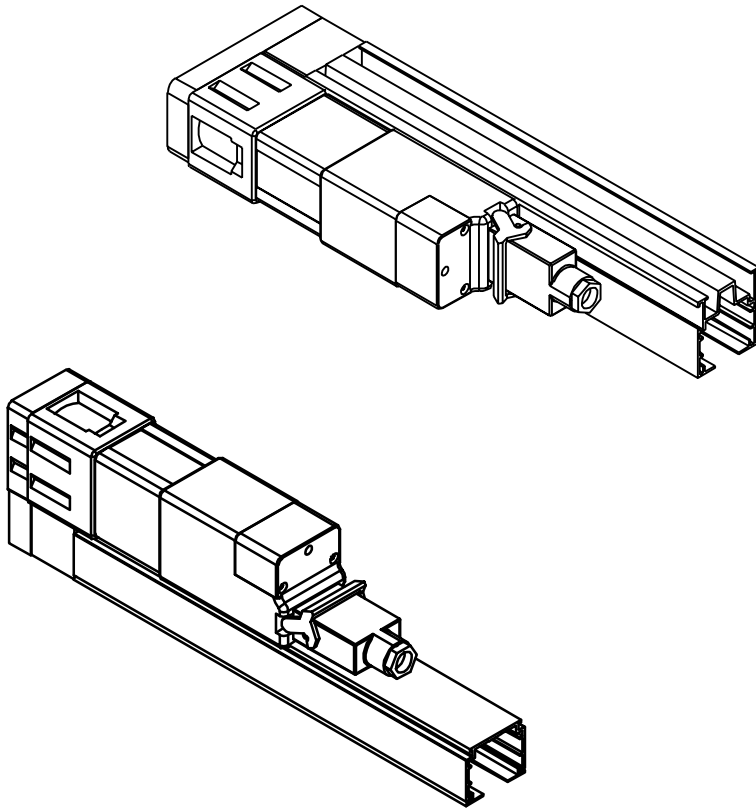

## Installation Instructions for Vertical Systems

**Verticals**

**Tools Required:**

Power Screwdriver

Extended Phillips  
bit for the  
power screwdriver

Needle Nose Pliers

Wire Cutters

Flathead Screwdriver

Small Phillips

Small Flathead

Test Cable

Allen wrench set

Screws & Anchors

**Also Perhaps:**

Shims

# Table of Contents

Installing the Vertical Systems

- Slenderline . . . . . 3
- Slimline . . . . . 4

Pocket Drawing . . . . . 5

Limit Adjustment Instructions for Verticals . . . . . 6

Basic Switch Control Wiring. . . . . 7

Maintenance Instructions for Verticals. . . . . 7

Warranty . . . . . 8

# Installing the Slenderline

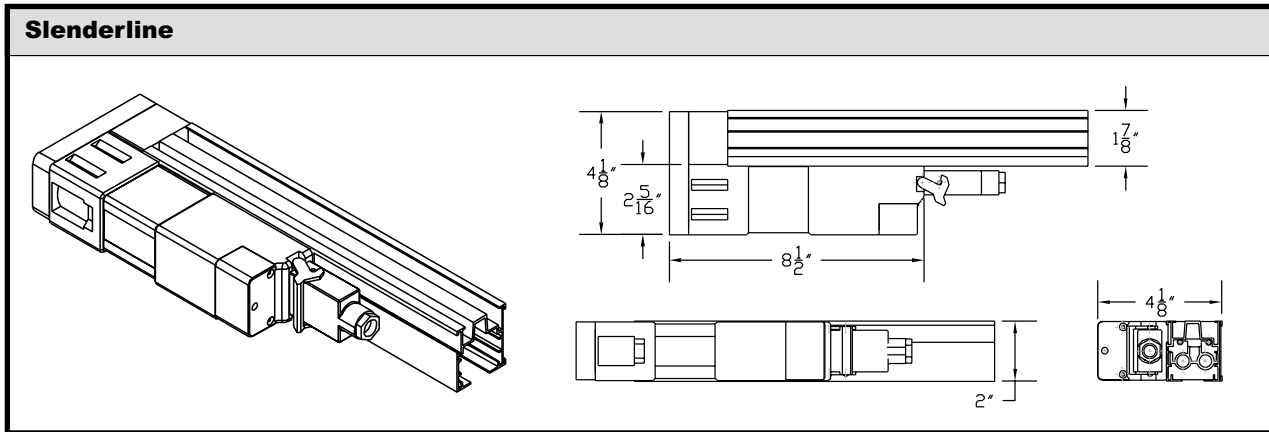

The Slenderline headrail may either be ceiling mounted using the screw channel (**Fig. 1**), or can be wall mounted using the brackets supplied. Due to the various building materials used in construction, i.e. concrete, dry wall or wood, we do not supply the fasteners or screws.

## Ceiling Mount

1. Secure headrail to the mounting surface by running fasteners through the screw channel located in the center of the rail. (**See Fig.1**) Fasteners should be located at each end and at 18" intervals throughout the rest of the rail.
2. Limits are preset at factory using a test cable, run system prior to attaching the vanes to the carriers. If system runs smoothly, proceed to #3; if not, call factory for assistance in adjusting the limits of the motor.
3. Attach one or two vanes to the lead carrier and test system again checking both the traversing and rotation functions. If the system runs smoothly, attach remaining vanes and test again.
4. Wire the system to the existing prewired pigtail (provided by BTX). If using the plug-in option, just plug control into motor and then into outlet.

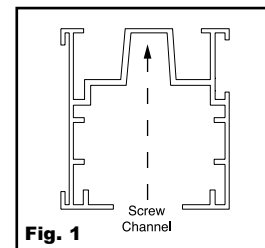

**Fig. 1**

## Wall Mount

1. Using the hardware provided, attach the headrail wall bracket mount to the L-bracket. The wall bracket mount can be easily moved down the headrail via the Allen screw located underneath the mount. (**See Fig. 2**)
2. Limits are preset at factory using a test cable, run system prior to attaching the vanes to the carriers. If system runs smoothly, proceed to #3; if not, call factory for assistance in adjusting the limits of the motor.
3. Attach one or two vanes to the lead carrier and test system again checking both the traversing and rotation functions. If the system runs smoothly, attach remaining vanes and test again.
4. Wire the system to the existing prewired pigtail (provided by BTX). If using the plug-in option, just plug control into motor and then into outlet.

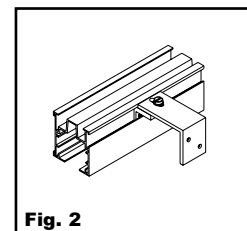

**Fig. 2**

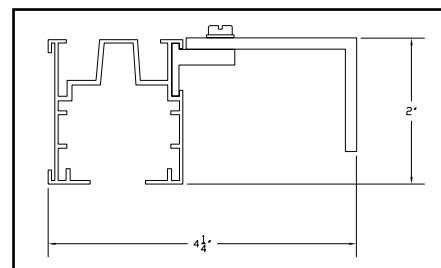

# Installing the Slimline

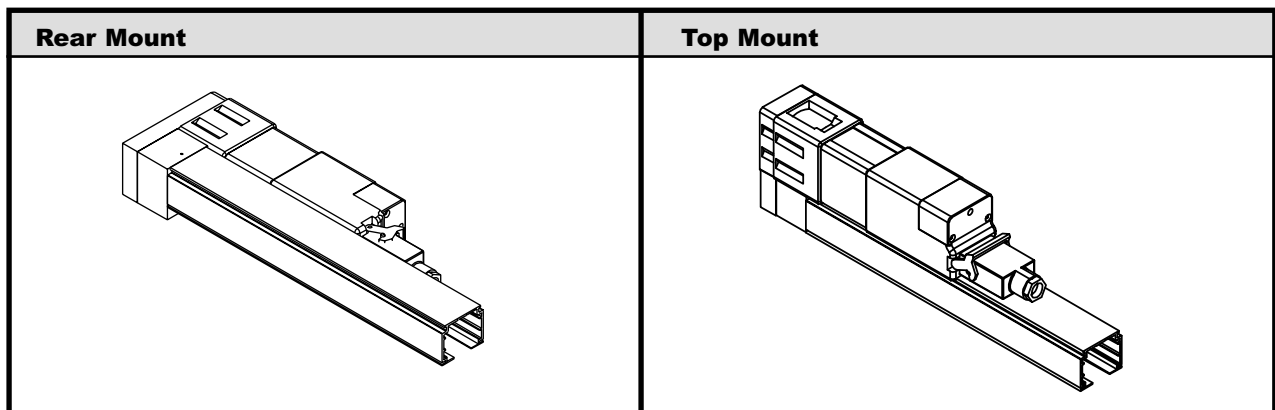

The Slimline headrail may either be ceiling mounted using the ceiling clips (**Fig.1**), or can be wall mounted using the brackets supplied. Due to the various building materials used in construction, i.e. concrete, dry wall or wood, we do not supply the fasteners or screws.

## Ceiling Mount

When ceiling mounting the Slimline Vertical headrail, certain steps must be taken to have a successful installation.

- Whether you are using a rear mounted motor system or a top mounted motor system, the brackets will have to be shimmed out for a specific distance.  
Rear mount = 9/16" additional. Top mount = 2-5/16" additional.
- Attach ceiling clip to the solid mounting surface with fasteners provided. Make sure brackets are in-line with each other.
- Insert the track with the groove of the track into lip of clip and rotate the track into the other end of the clip until it snaps into place.
- Limits are preset at factory using a test cable, run system prior to attaching the vanes to the carriers. If system runs smoothly, proceed to #3; if not, call factory for assistance in adjusting the limits of the motor.
- Attach one or two vanes to the lead carrier and test system again checking both the traversing and rotation functions. If the system runs smoothly, attach remaining vanes and test again.
- Wire the system to the existing prewired pigtail (provided by BTX). If using the plug-in option, just plug control into motor and then into outlet.

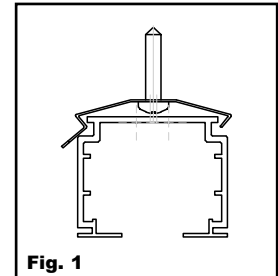

## Wall Mount

- Using the wall brackets provided, attach L-brackets to solid blocking with fasteners. Provide brackets at each end of track and then every 18"-24".
- Insert the track with the groove of the track into lip of clip and rotate the track into the other end of the clip until it snaps into place.
- Limits are preset at factory using a test cable, run system prior to attaching the vanes to the carriers. If system runs smoothly, proceed to #3; if not, call factory for assistance in adjusting the limits of the motor.
- Attach one or two vanes to the lead carrier and test system again checking both the traversing and rotation functions. If the system runs smoothly, attach remaining vanes and test again.
- Wire the system to the existing prewired pigtail (provided by BTX). If using the plug-in option, just plug control into motor and then into outlet.

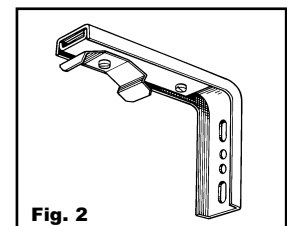

# Pocket Drawing

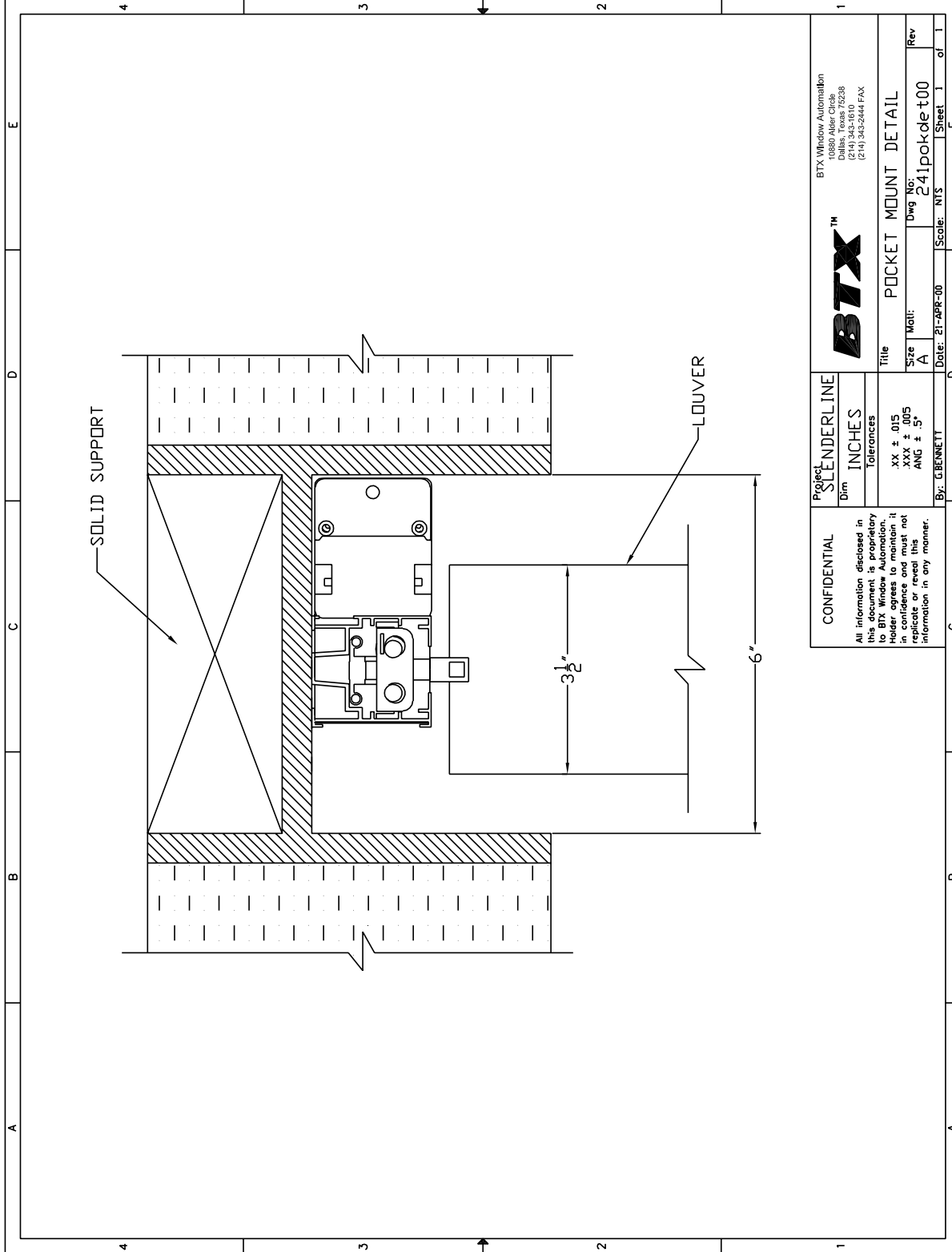

<p><b>CONFIDENTIAL</b></p> <p>All information disclosed in this document is proprietary to BTX Window Automation. Reproduction, distribution, or disclosure in any manner, in complete or partial, is prohibited and may result in legal action.</p>	<p>Project: <b>SLENDERLINE</b></p>		<p>BTX Window Automation 10880 Allice Circle Houston, TX 77036 (214) 343-1810 (214) 343-2444 FAX</p>		
	<p>Dim: <b>INCHES</b></p>		<p><b>BTX</b>™</p>		
	<p>Tolerances: XX ± .015 XXX ± .005 ANG ± .5°</p>		<p>Title: <b>POCKET MOUNT DETAIL</b></p>		
	<p>By: <b>G.BENNETT</b></p>		<p>Date: <b>21-APR-00</b></p>		
		<p>Scale: <b>NIS</b></p>		<p>Dwg No: <b>241pocket00</b></p>	
		<p>Sheet <b>1</b> of <b>1</b></p>		<p>Rev <b>1</b></p>	

# Limit Adjustment Instructions

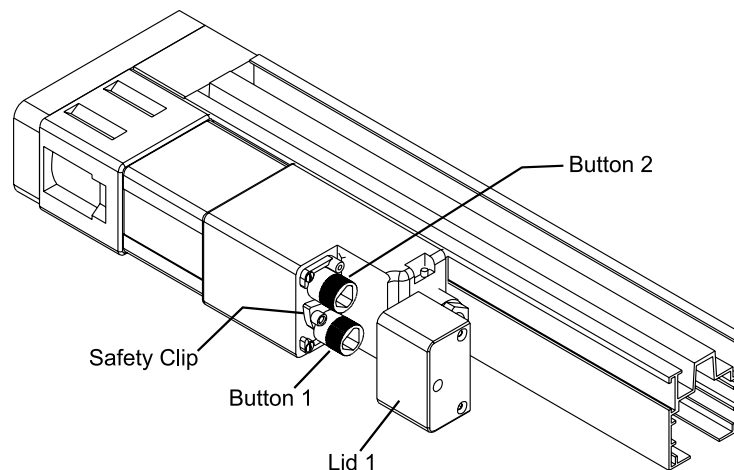

The following instructions are intended for use where a minor adjustment of the limits is required to accommodate the stacking requirements of the drapery, or where the original size of the system has been altered in the field per BTX instructions. For adjustments to be made, the motors must be running on the tracks, and a test cable should be used for this purpose.

1. All tracks and motors have been numbered at the factory prior to shipping. Verify that the motor and track numbers match before you attempt to set the limits. If track and motor are mismatched, it could result in the limit buttons controlling the function opposite to those for which they are labeled.
2. Install motor(s) on the appropriate track, and lock into place. If track is a Tandem motor system, attach drive motor and non-drive motor to track and plug in Tandem wiring harness to motors. Drive and non-drive motors, endcaps and plugs are labeled accordingly. Make certain they match up.
3. Locate limit buttons inside lid 1 by removing three Phillips head screws. Tandem motor systems have limits on drive motors only. Limit buttons are marked for the function they control stack and close.
4. Run the track in the direction the adjustment needs to be made. At the same time, observe the direction that the limit button to be adjusted is turning.
  - A. If the motor shuts off before reaching the intended location, push the safety clip to one side, push the limit knob in, and carefully turn it in the opposite direction. The motor should immediately begin to advance in the direction it was running before shutting off. When it reaches the correct stopping point, carefully pull the button out and lock it into place with the safety clip. Hand tighten a screw into safety clip to ensure limits will not adjust themselves. Test run to verify that the limit is set.
  - B. In the event that the motor is running past where it should shut off, shut it off manually with the switch at the desired stopping point. Push the safety clip to one side and push in the limit button to be adjusted. Carefully turn the button in the same direction it was turning before being shut off. Watch and listen for the limit switch to drop into the recessed portion of the cams. When the limit switch can be seen engaging or makes an audible clicking sound, carefully pull the button out and lock it into place with the safety clip. Hand tighten a screw into safety clip to ensure limits will not adjust themselves. Test run to verify that the limit is set.

**NOTE: When running a Tandem motor system, power from the switch should be applied to the wiring harness supplied with the track not directly to the drive motor.**

# Basic Switch Wiring

Illustrated below is the basic wiring diagram for the Motorized Verticals.

**Caution! Do not wire** motors in parallel!

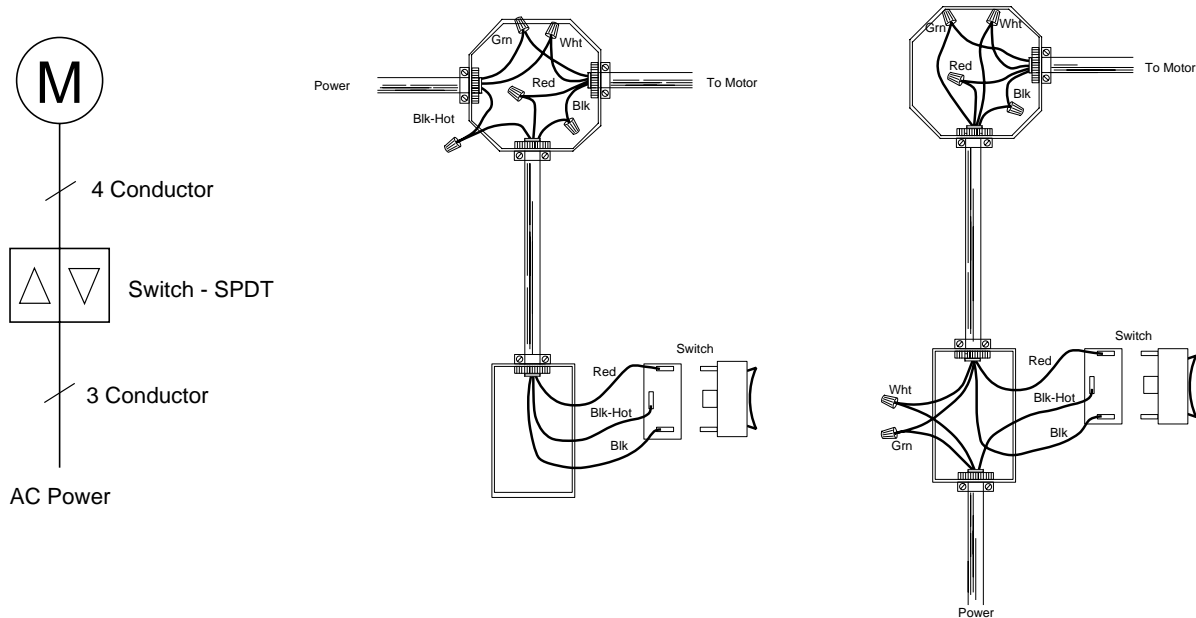

## Maintenance for Vertical Blinds

### Storage

Prior to installation, units should be stored in original packaging, in an area free from moisture and dust.

### Installation

Upon installation the units should be tested for proper operation and any necessary adjustments made.

### Operation

The units should be lubricated every 12 months after installation. A light to medium weight high quality silicon should be sprayed throughout the inside of the track from end to end. Both shafts and carrier wheels should be coated with a light film of spray as well. The motor gear can be lubricated by directing the spray into the location marked below. The internal parts of the motor have been built with a lifetime lubrication.

# Warranty & Return Policy

## 1. Contract

All offers, quotes and sales by BTX Window Automation, Inc. (BTX) are subject to these Terms and Conditions of Sale. No other agreements have been made or will be valid unless expressly confirmed in writing by BTX.

## 2. Acceptance

**BY TAKING DELIVERY OF BTX PRODUCTS, PURCHASER ASSENTS TO THE TERMS AND CONDITIONS STATED HEREIN, UNLESS OTHERWISE EXPRESSLY AGREED IN WRITING BY BTX. BTX HEREBY OBJECTS TO ANY DIFFERENT OR ADDITIONAL TERMS AND CONDITIONS WHICH MAY BE PROPOSED OR HAVE BEEN PROPOSED BY PURCHASER IN ANY PURCHASE ORDER FORMS OR OTHER DOCUMENTS. THE TERMS AND CONDITIONS STATED HEREIN SHALL PREVAIL OVER ANY DIFFERENT OR ADDITIONAL TERMS AND CONDITIONS PROPOSED BY PURCHASER AND SHALL APPLY TO THE SALE OR SHIPMENT OF ANY GOODS IN RESPONSE TO PURCHASER'S ORDER.**

## 3. Prices and Delivery

All quoted prices are valid for a period of 60 days from the date of issue, unless otherwise agreed by BTX in writing. Prices on accepted orders remain firm for a period of four months from the date of order acceptance, provided final delivery occurs within that period. If delivery is to occur more than four months from the date of order acceptance, prices are subject to change in accordance with any changes in the published BTX price list which occur after the date of order acceptance. All prices quoted are FOB Dallas, excluding all freight, packaging and taxes. All delivery dates are approximate.

## 4. Payment Terms

(a) Open account payment terms may be established from time to time at the sole discretion of BTX, and are subject to credit approval in writing. Terms on open accounts are payment in full, net 30 days from date of invoice. Payment terms for single transactions and transactions other than on open account are net C.O.D. or prepay unless confirmed otherwise in writing by BTX.

(b) Amounts past due are subject to a finance charge of 1.5% per month to the legal limit, and the finance charge will apply without further prior notice. In case of purchaser's delinquency in payment or insolvency, BTX retains the right to halt or interrupt all further deliveries and service to the purchaser until all past due amounts have been paid, and to require payment in advance for orders not yet delivered, without any liability resulting for BTX. Purchaser expressly agrees to indemnify BTX and hold BTX harmless from all charges and liability which might arise in any manner from purchaser's nonpayment.

## 5. Inspection, Acceptance and Claims

All claims by purchaser against BTX for shortages must be made in writing to BTX within fourteen days from date of shipment from BTX's Dallas base or they are waived. Any claims for transport damage are the responsibility of the recipient and must therefore be filed with the carrier by the recipient.

## 6. Risk of Loss

Full risk of loss, damage or destruction of the goods shall pass to purchaser upon delivery of the goods to the carrier at the point of shipment or upon delivery at storage, whichever applies.

## 7. Force Majeure

If an order cannot be completed due to causes

beyond BTX's control, BTX retains the right to either cancel the uncompleted portion of the order or complete the order if and when this becomes possible. Purchaser shall not have the right to withhold payment on delivered goods and/or services, nor to unilaterally change the order or cancel same. Force majeure includes but is not limited to strikes, lock-outs, storms, floods and the like, terrorism, wars, revolutions, major equipment failures or fire damage at production facilities, etc.

## 8. Warranty

BTX extends a three-year limited warranty for its MotorDrape™ DC systems and controls. BTX warrants its other systems and 110/220V motors and hardware accessories against defects in material and workmanship for a period of five years from date of shipment from BTX's Dallas base; however, pull chains and cords for roller shades are excluded. BTX controls and electric and electronic components carry a one-year warranty against defects in material and workmanship from date of shipment from BTX's Dallas base. BTX does not warrant cords and tapes for lift systems, nor customer's own materials, and BTX disclaims any written, oral or implied warranties for such materials. If any item to which a warranty applies proves to be defective during the specified warranty period under normal and proper use and provided the equipment or part has been properly stored, installed and maintained with due regard to any directives, instructions and operating procedures provided, BTX shall, upon presentation of proof of purchase, repair or replace the item at the sole option of BTX, F.O.B. Dallas. Application of the warranty will be determined by BTX technical staff after return of the item, its inspection and any necessary investigation. This warranty does not apply in case of defects resulting from faulty installation, misuse, misapplication, abuse, mishandling, shipping or failure to follow instructions. This warranty does not cover any incidental, special or consequential damages, labor on location, service calls, reinstallation, or expenses involved in shipping, packing, and returning the goods. It also does not cover damages caused by fire, flood, or act of God. BTX warrants items repaired or replaced pursuant to the above warranty, under normal and proper use, storage, installation and maintenance, against defects in material and workmanship for a period of 30 days from date of start-up of such repaired or replaced item or the expiration of the original warranty, whichever is longer. Correction of non-conformities in the manner and for the period of time specified herein shall be purchaser's exclusive remedy and shall constitute fulfillment of all liabilities of BTX, whether in warranty, contract, negligence, tort, or otherwise with respect to the item delivered. In no event shall BTX be responsible for providing access to the allegedly defective item or for disassembly or reinstallation of such item or parts.

## 9. DISCLAIMER

**THE FOREGOING EXPRESS WARRANTIES ARE EXCLUSIVE AND IN LIEU OF ALL OTHER WARRANTIES, WRITTEN, ORAL OR IMPLIED. ALL OTHER WARRANTIES, INCLUDING ANY WARRANTY OF MERCHANTABILITY OR FITNESS FOR A PARTICULAR PURPOSE, ARE HEREBY DISCLAIMED.**

## 10. LIMITED LIABILITY

BTX'S LIABILITY FOR ANY AND ALL CLAIMS, CHARGES, EXPENSES, DAMAGES, LOSSES AND INJURIES ARISING OUT OF OR RELATING TO ITS PERFORMANCE OR BREACH OF

ANY AGREEMENT OF SALE FOR GOODS AND/OR THE MANUFACTURE, SALE, DELIVERY, RESALE, REPAIR OR USE OF ANY GOODS SHALL NOT EXCEED THE PURCHASE PRICE OF SUCH GOODS, REGARDLESS WHETHER THE CLAIM IS BASED ON CONTRACT, TORT, NEGLIGENCE, STATUTE, STRICT LIABILITY, WILLFUL OR WANTON CONDUCT, WARRANTY (EXPRESS OR IMPLIED), OR OTHERWISE. THIS SHALL BE PURCHASER'S SOLE AND EXCLUSIVE REMEDY AGAINST BTX OTHER THAN THE REMEDY PROVIDED FOR UNDER THE EXPRESS BTX WARRANTIES. IN NO EVENT SHALL BTX BE LIABLE FOR INCIDENTAL, SPECIAL, CONSEQUENTIAL OR EXEMPLARY DAMAGES.

## 11. ARBITRATION

BTX AND PURCHASER AGREE THAT THIS TRANSACTION INVOLVES INTERSTATE COMMERCE AND THAT AT THE OPTION OF BTX, ANY DISPUTE RELATING TO IT IN ANY MANNER SHALL BE SUBMITTED TO BINDING ARBITRATION BEFORE THE AMERICAN ARBITRATION ASSOCIATION AND SHALL BE GOVERNED BY THE FEDERAL ARBITRATION ACT OR, IF THAT STATUTE IS INAPPLICABLE, ANY DISPUTE SHALL BE GOVERNED BY THE TEXAS ARBITRATION ACT; HOWEVER, NO ARBITRATOR MAY AWARD PUNITIVE DAMAGES. PURCHASER AGREES TO PAY ALL COSTS INCURRED BY BTX, INCLUDING BUT NOT LIMITED TO COSTS OF ARBITRATION, COLLECTION, REASONABLE ATTORNEY'S FEES, EXPENSES AND ANY COURT COSTS.

## 12. Return

No goods may be returned without the express written approval of BTX and the receipt of an BTX RGA identification number. Goods approved for return must be returned in original packaging, freight prepaid, clearly marked with the BTX RGA identification number and be accompanied by a copy of the original invoice. Application of the warranty will be determined by BTX technical staff after return of the item, its inspection, and any necessary investigation. A restocking charge of 25% of invoice value will apply on all items accepted for return.

## 13. Liens and Security Interest

Purchaser will not permit to be created or to remain undischarged any lien, encumbrance or charge upon the goods supplied by BTX until BTX has received payment in full for such goods. If any liens, encumbrances or charges shall be filed against BTX goods prior to payment in full, purchaser shall discharge the liens, encumbrances or charges within ten days and reimburse BTX for expenses incurred in defending its security interest. Title to the goods shall remain with BTX until payment in full has been received.

## 14. Statute of Limitations

Any action against BTX shall be commenced within one year after the cause of action has arisen.

## 15. Choice of Law and Venue

The rights and duties of the parties hereunder and the construction and effect of these terms and conditions shall be governed by the laws of the State of Texas. Venue shall lie in Dallas, Texas, to the exclusion of any other jurisdiction.

16. This agreement supersedes any inconsistent or additional promises made by any employee, representative, agent or dealer of BTX.

17. If any part of this agreement is found invalid, the balance of the agreement remains enforceable.

WTY-030806